

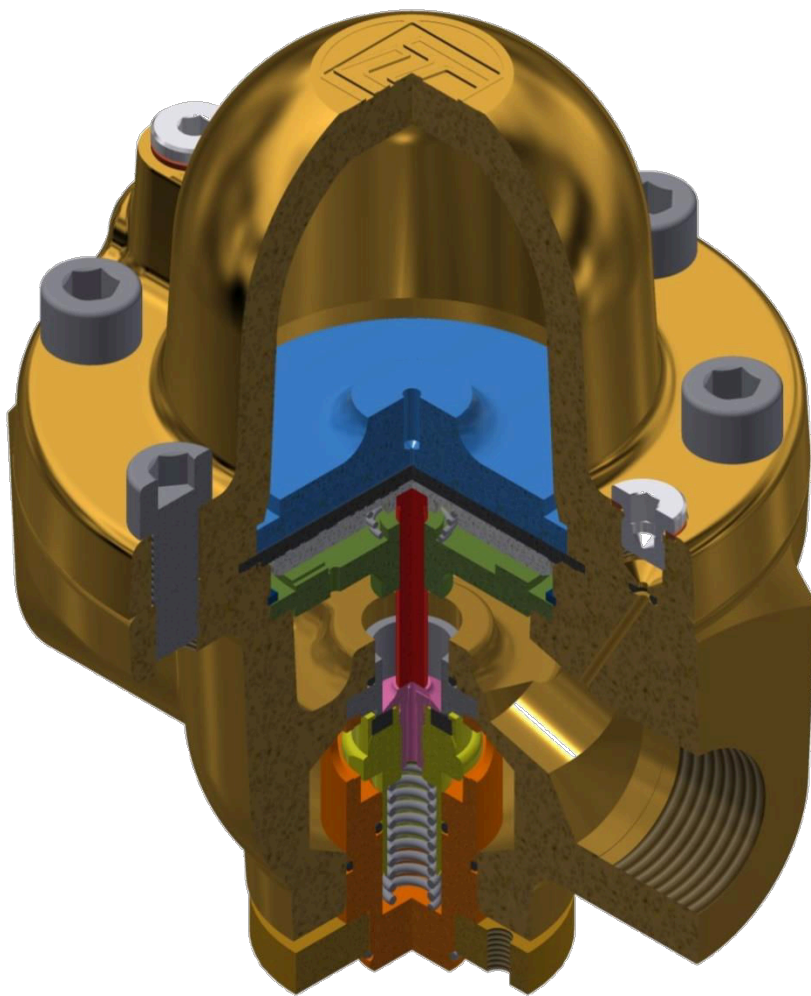

Dome loaded pressure controller, units and panels



Pressure control
beyond standards



Pressure controller from LT GASETECHNIK

Process gas supply with high pressure consistency even when the inlet pressures and flow rates vary as well as with low pressure differences.

Features and advantages

- Defined, uniform outlet pressure, unaffected by fluctuations in inlet, outlet pressure or flow rate.
- No "fluttering", even with large inlet pressure fluctuations due to the **particularly large dome chamber** with large compressible **gas pressure accumulator**
- For pipe installation or as a manifold
- **Wide performance range:** 10... 2,500 Nm³/h due to minimal Δp
- Large working pressure range and no two-stage pressure control necessary due to adapted pressure ranges: low pressure, medium pressure, high pressure
- Flexible operation:
 - Locally with own or external medium
 - Remotely controlled with electronically controllable pilot controller
- Short delivery times - standards available from stock
- Complete solutions, assembled and tested ex works:
 - Pressure control unit with manometer and pilot pressure controller
 - Pressure control system with bypass and shut-off valves
 - Remote controllable dome loaded pressure controller
 - Individual configuration

*Precise and und instantaneous pressure control
Without fluttering, even at large variations*

Application areas

When it comes down to the **particularly uniform outlet pressure**, dome loaded pressure controllers show their strengths. In contrast to the simple pressure controller with steel spring, the dome loaded pressure controller uses a compressible gas (own or external medium). This gas pressure accumulator achieves a sensitive response without self-damping and without spring characteristic curve.

That is why LT dome pressure controllers have a particularly **large dome chamber**.

Large dome chamber = high control accuracy

Versions type specific, associated details in the corresponding data sheet:

Media

- Technical gases, flammable and non-flammable, e.g. N₂, O₂, CO₂, H₂, Ar, etc.
- Hydrocarbons like Natural Gas, Propane, and Butane etc.
- Technical air
- Liquids

Media-dependent use of sealing materials made of EPDM or Viton.

Pressure

- Low pressure:
 - Inlet pressure 25 barg
 - Outlet pressure: 0.1 ... 24 barg
- Middle pressure:
 - Inlet pressure to 100 barg
 - Outlet pressure 0.5...99 barg
- High pressure:
 - Inlet pressure to 414 barg
 - Outlet pressure 28...138 barg

Temperature

- Viton: -20°C ... 100 °C
for O₂, and all gases except acetylene and CO₂
- EPDM in LTD-1: -40°C ... 130 °C
for CO₂ and all neutral gases
- EPDM in LTD-2 and LTD-3: -20°C ... 70 °C
for CO₂ and all neutral gases



Design

- Brass, Stainless Steel, Brass Nickel plated or Alumina
- Threaded connection 1", 2" or 3" or flange connection

Certificates

LT GASETECHNIK is certified according to DIN ISO 9001:2015 and DGRL 2014/68/EU Module A2.

LT Dome loaded pressure controllers

- Are depending on the application, according to DIN EN 1127-1, DIN EN ISO 80079-36 and GUV-R 132 suitable for flammable gases
- Comply with the European Framework Regulations (EG) 1935/2004 and (EG) 2023/2006
- Comply with the regulation DGRL 2014/68/EU
- meet optionally the requirements of the Food, Consumer Goods and Feed Code (LFGB)
- are suitable for usage with O₂, have BAM approved non-metallic materials



LTD-1 ND Stainless Steel

Design principle dome loaded pressure controller

Illustrated at the example of the LTD-1 MD, Brass.

Analogue design principle with other dome loaded pressure controllers from LT.

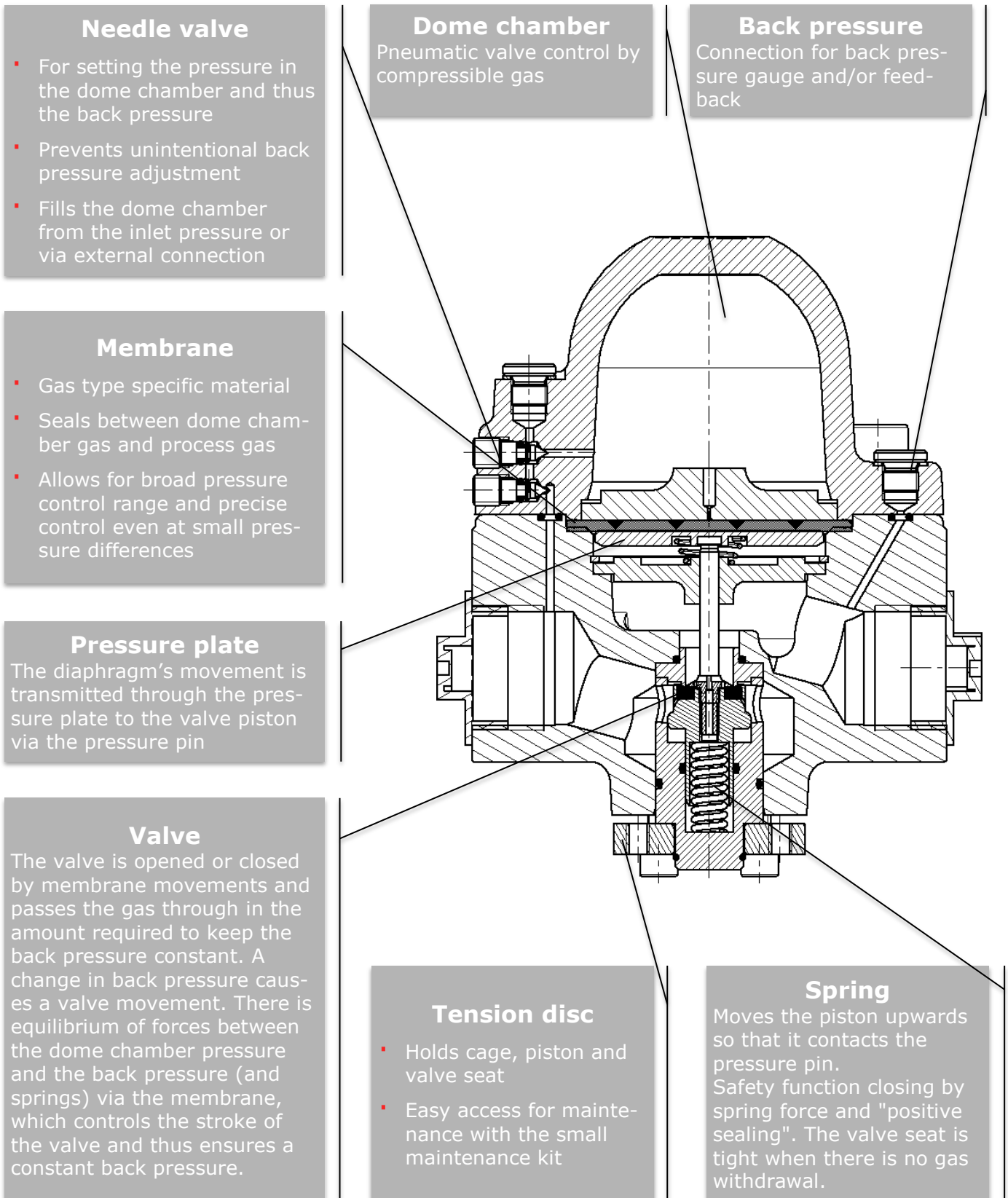

Supply range

Material	Con- nection	Inlet pres- sure [barg]	Outlet pressure range [barg]	Kv	Install- ation length	Weight	Seal	Art-No
Brass	1"	25	0.1...24	2.9	127 mm	6 kg	Viton	3-7020
	1"	25	0.1...24	2.9	127 mm	6 kg	EPDM	3-7060
	1"	100	0.5...99	2.9	127 mm	6 kg	Viton	3-7010
	1"	100	0.5...99	2.9	127 mm	6 kg	EPDM	3-7050
Brass f. O₂, cleaned	1"	25	0.1...24	2.9	127 mm	6 kg	Viton	3-7252
	1"	40	0.5...39	2.9	127 mm	6 kg	Viton	3-7003
Nickel plat- ed	1"	100	0.5...99	2.9	127 mm	6 kg	Viton	3-7000
	1"	100	0.5...99	2.9	127 mm	6 kg	EPDM	3-7001
Stainless Steel	1"	25	0.1...24	2.9	127 mm	13 kg	Viton	3-7040
	1"	25	0.1...24	2.9	127 mm	13 kg	EPDM	3-7080
	1"	100	0.5...99	2.9	127 mm	13 kg	Viton	3-7030
	1"	100	0.5...99	2.9	127 mm	13 kg	EPDM	3-7070
Stainless Steel High pressure	1"	414	28...138	1.8	110 mm	9.9 kg	Viton	3-7610
Alumina- alloy	2"	69	0,7...65	8.3	222 mm	6.4 kg	EPDM	3-7600

- LTD-1: Acetylene outlet max. 1.5 barg
- Connection inlet and outlet: G 1" RH female
- The performance diagram can be found in the respective data sheet



Dome loaded pressure controller out of Brass

Oxygen	Acetylene	Natural-CO	Other technical gases	Max. performance	Max. Inlet pressure	Outlet pressure adjustable	Pressure range	Elastomer	Art-No.
X				$p_2/p_1 < 0.5$: at $p_2 = 40$ barg: 2100 Nm ³ /h	Oxygen: 40 barg	Oxygen: 0.5...39 barg			3-7003
			X	$p_2/p_1 < 0.5$: at $p_2 = 40$ barg: 2100 Nm ³ /h	100 barg	other gases: 0.5..99 barg	MD	Viton	3-7010
X				$p_2/p_1 < 0.5$: at $p_2 = 12$ barg: 700 Nm ³ /h	25 barg	0.1...24 barg			3-7252
			X	$p_2/p_1 < 0.5$: at $p_2 = 12$ barg: 700 Nm ³ /h	25 barg	0.1...24 barg	ND	Viton	3-7020
		X	X	$p_2/p_1 < 0.5$: at $p_2 = 40$ barg: 2100 Nm ³ /h	100 barg	0.5...99 barg	MD	EPDM	3-7050
	X	X	X	$p_2/p_1 < 0.5$: at $p_2 = 12$ barg: 700 Nm ³ /h	25 barg	0.1...24 barg	ND	EPDM	3-7060

Maintenance sets for dome loaded pressure controller out of Brass

Product	Oxygen	Acetylene	Natural-CO	Other technical gases	Pressure range	Elastomers	Art-No.
Maintenance kit small				X	MD	Viton	3-7041
				X	ND	Viton	3-7059
			X	X	MD	EPDM	3-7065
		X	X	X	ND	EPDM	3-7066
	X			X	MD	Viton	3-7226
	X			X	ND	Viton	3-7259
Maintenance kit large				X	MD	Viton	3-7016
				X	ND	Viton	3-7044
			X	X	MD	EPDM	3-7043
		X	X	X	ND	EPDM	3-7067
	X			X	MD	Viton	3-7061
	X			X	ND	Viton	3-7258

Note: Scope of delivery of maintenance kits on the next page.

The moving parts of the LTD-1 are combined in the maintenance kit and should be replaced regularly. We recommend checking for leaks and maintenance with the "maintenance kit small" at least **once a year**. We recommend replacing the membrane after 5 years with the „maintenance kit large"

Maintenance kit small for LTD-1,
 consists of

- 1: Seal ring
- 2: Valve seat
- 3: Valve screw
- 4: Flat seal
- 5: Valve piston
- 6: Valve compression spring
- 7: Seal ring
- 8: Valve guide
- 9: Seal ring

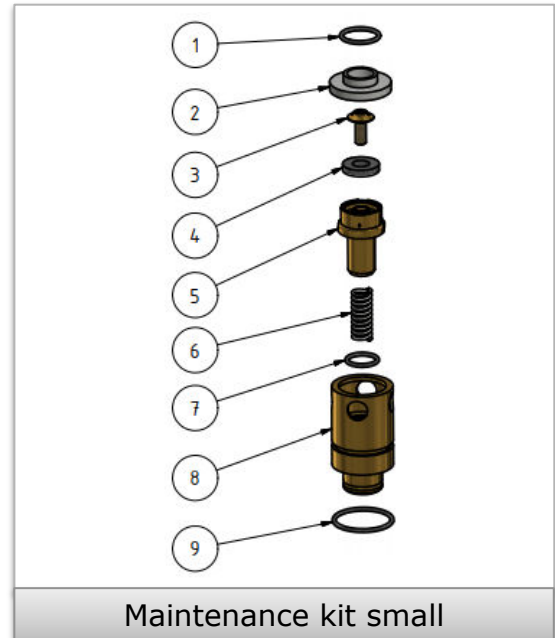

Maintenance kit large for LTD-1,
 consists of

- 1: Seal ring
- 2: Needle valve
- 3: Membrane
- 4: Spring conical (only for MD)
- 5: Seal ring
- 6: Valve seat
- 7: Valve screw
- 8: Flat seal
- 9: Valve piston
- 10: Valve compression spring
- 11: Seal ring
- 12: Valve guide
- 13: Seal ring
- 14: Support ring for Membrane (only for at ND)
- 15: 2 Seal rings (not shown)

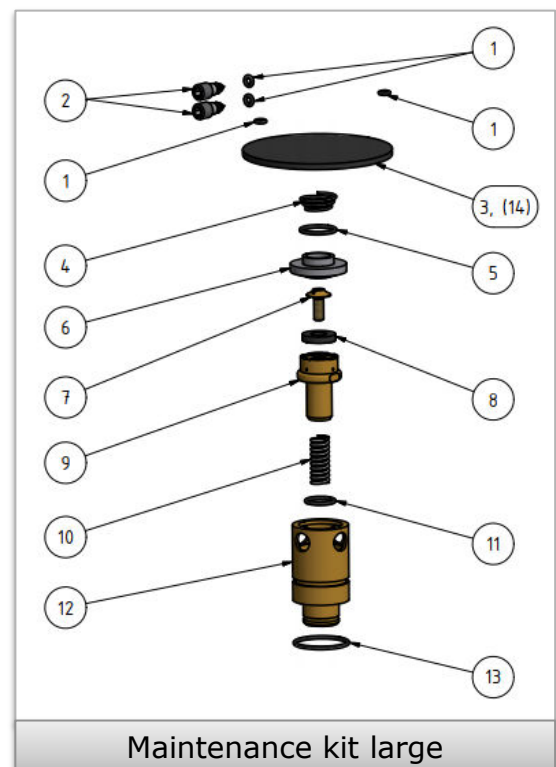

LTD-1 Dome loaded pressure controller can be maintained in our works, for a small maintenance charge including suitable maintenance kit. Dome loaded pressure controllers of other producers, e.g. Buschjost/IMI/GHR Types C1 and C31, can as well be maintained by LT for a lump sum including suitable maintenance set. Please contact us.

Dome loaded pressure controller out of Stainless Steel

Oxygen	Acetylene	Natural-CO	Other technical gases	Max. performance	Max. Inlet pressure	Outlet pressure adjustable	Pressure range	Elastomer	Art.-no.
X			X	$p_2/p_1 < 0.5$: at $p_2 = 40$ barg: 2100 Nm ³ /h	Oxygen: 40 barg Other gases: 100 barg	Oxygen: 0.5...39 barg other gases: 0.5...99 barg	MD	Viton	3-7030
X			X	$p_2/p_1 < 0.5$: at $p_2 = 12$ barg: 700 Nm ³ /h	25 barg	0.1...24 barg	ND	Viton	3-7040
		X	X	$p_2/p_1 < 0.5$: at $p_2 = 40$ barg: 2100 Nm ³ /h	100 barg	0.5...99 barg	MD	EPDM	3-7070
	X	X	X	$p_2/p_1 < 0.5$: at $p_2 = 12$ barg: 700 Nm ³ /h	25 barg	0.1...24 barg	ND	EPDM	3-7080

Maintenance sets for pressure controller out of Stainless Steel

Product	Oxygen	Acetylene	Natural-CO	Other technical gases	Pressure range	Elastomers	Art.-no.
Maintenance kit small :	X			X	MD	Viton	3-7071
	X			X	ND	Viton	3-7072
			X	X	MD	EPDM	3-7073
		X	X	X	ND	EPDM	3-7074
Maintenance kit large :	X			X	MD	Viton	3-7075
	X			X	ND	Viton	3-7076
			X	X	MD	EPDM	3-7077
		X	X	X	ND	EPDM	3-7078

Note: Scope of delivery of maintenance kits on the previous page.

Accessories LTD-1

For dome loaded pressure controller LTD-1 Stainless Steel or Brass, middle pressure or low pressure (up to the maximum inlet pressure of 100 barg) we offer the following accessories:

- Screw-in connection DN25/PN40, G1" a - D 28 mm, Brass
 - for pipe outer diameter = 28 mm
 - Material Brass
 - Incl. seal ring Viton with Oxygen-service
 - Art.-no. 3260503

- Double threaded joint
 - Both sides G1" RH external thread
 - PN 100
 - Stainless Steel incl. suiting seal ring
 - Art.-no. 3-7401

- Wall mount
 - For safe and tension-free mounting
 - Steel, coated, 100x140x80 mm
 - Art.-no. 3-7015

- Loose type flange DN25 PN40 Stainless Steel/Brass:
 - Flange, rotating DN25 PN40, Stainless Steel 1.4571
 - Mounting boss G1", Brass including suiting seal ring
 - Art.-no. 1-4070

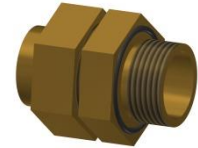

Screw-in connection



Double threaded joint



Wall mount



Loose flange SS/B

- Loose type flange DN25 PN40
Stainless Steel/Stainless Steel:
 - Flange, rotating DN25 PN40,
 - Stainless Steel 1.4571
 - Mounting boss G1",
Stainless Steel including suiting seal ring
 - Art.-no. 1500018



Loose flange SS/SS

- Extension Brass
 - Thread extension G1" RH, Brass
 - including suiting seal ring
 - Art.-no. 3-7257

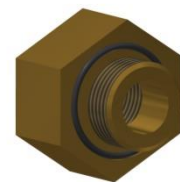

Extension B

- Extension Stainless Steel
 - Thread extension G1" RH,
1.4404 or 1.4571
 - including suiting seal ring
 - Art.-no. 2048011

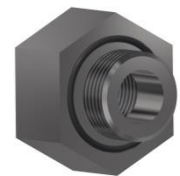

Extension SS

- Gas filter GR 40
 - Housing: Brass or Stainless Steel
 - Filter: Microplast 20 µm, Stainless Steel 80 µm,
Bronze 100 µm or 200 µm
 - Connections G1" IG RH,
inlet and outlet
 - PN25 20 µm: 3-0853
 - PN40 200 µm: 3-0864



Gas filter B

- Certificates
 - Factory certificate Type 2.1 acc. EN 10204:
Art.-no. 6-2100
 - Test report Type 2.2 acc. EN 10204:
Art.-no. 6-2200
 - Inspection certificate 3.1 acc. EN 10204:
Art.-no. 6-3100

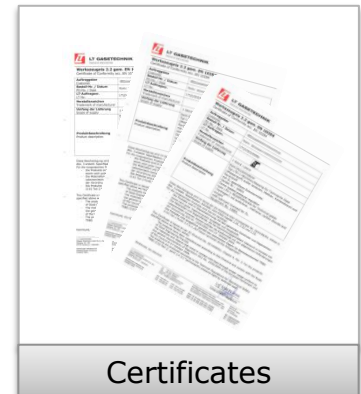

Accessories LTD-2

- Lose flange DN50 PN40 Stainless Steel/Brass:
 - Flange, rotating DN50 PN40,
Stainless Steel 1.4571
 - Mounting boss G1",
Brass including suiting seal ring
 - Art.-no. 3-7700

- Maintenance set for LTD-2
 - Art.-no. 3-7700

- Certificates
 - Factory certificate Type 2.1 acc. EN 10204:
Art.-no. 6-2100



Industry of things - IOT

- Pressure control unit type 3 with outlet pressure transmitter with local display



- Pressure control unit type 4, completely in Stainless Steel and outlet pressure transmitter with local display



- Dome loaded pressure controller with electronic controllable proportional valve for easy setting from the distance e.g. with a process control system. Configuration according to individual specifications



***LT develops with you the perfect solution!
Use our competence from the last 5 decades***



Modular system for LT pressure control panels

LT offers a modular system for easy compilation of your perfect solution. LT designs compact and completely ready for connection and operation. Your pressure control system is individually priced, offered, manufactured, and documented including certificate and operating instructions. This way you get a finished, 100% pressure-tested, and CE-compliant solution directly to your construction site to reduce installation and working time.

LT modular system:

- a) Piping: Soldered Copper or welded Stainless Steel
- b) Nominal size e.g. DN25, DN40, or DN50
- c) Dome loaded pressure controller 1", 2" or 3"
- d) Gas type and pressure specific
- e) Connections: Soldering screw joint, flange, open pipe end, or compression fitting
- f) Connection positions: top, down, or sideways
- g) Flow direction: To the right or to the left
- h) Ball valve(s): Inlet/outlet/bypass
- i) Gas filter/dirt trap – w/wo contamination indication
- j) Single or parallel pressure control units type 1-8 or bypass
- k) Inlet pressure and/or outlet pressure gauge in defined diameter w/wo shut-off valve
- l) Pressure transmitter w/wo local display
- m) Temperature transmitter w/wo sleeve
- n) Safety valve(es) per pressure controller/collective
- o) W/wo panel and/or stand for floor installation, w/wo roof
- p) Other options: pressure-relief valve, gas analyzer connection, emergency feed point, certificate(s)

***Modular system for the individual compilation,
tailor-made, finished and tested delivery***

Versions LTD-1

LTD-1 pressure control unit

- Dynamic control of the dome chamber pressure on basis of the LTD-1
- Compensation for temperature-related pressure fluctuations in the dome pressure chamber at type 1 to 8
- The outlet pressure has a regulating effect on the membrane of the pilot pressure controller, so that the valve seat opens or closes. Due to this the pressure control unit with external back pressure control (types 5 to 8) reacts faster and more sensible to demand fluctuations.



P1 max barg	Art-Nr	P2 max barg
25	3-8011	16
40	3-8012	25
50	3-8013	49

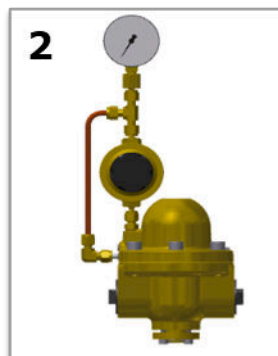

P1 max barg	Art-Nr	P2 max barg
25	3-8021	16
40	3-8022	25
50	3-8023	49

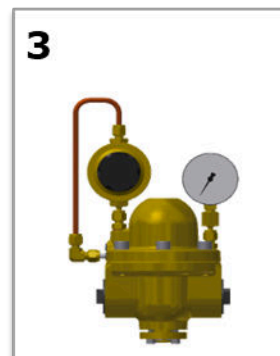

P1 max barg	Art-Nr	P2 max barg
25	3-8031	16
40	3-8032	25
50	3-8033	49

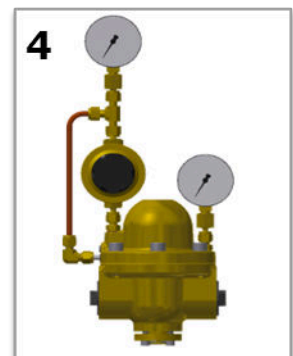

P1 max barg	Art-Nr	P2 max barg
25	3-8041	16
40	3-8042	25
50	3-8043	49



P1 max barg	Art-Nr	P2 max barg
40	3-8052	25
50	3-8053	49

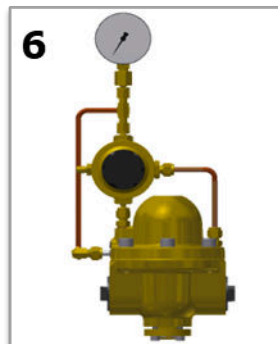

P1 max barg	Art-Nr	P2 max barg
40	3-8062	25
50	3-8063	49

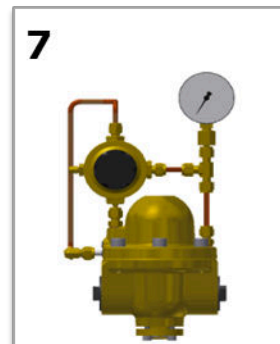

P1 max barg	Art-Nr	P2 max barg
40	3-8072	25
50	3-8073	49

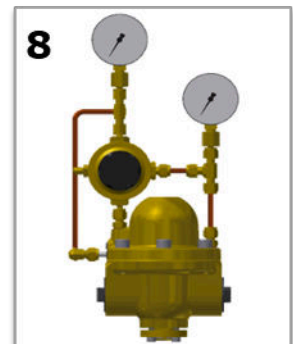

P1 max barg	Art-Nr	P2 max barg
40	3-8082	25
50	3-8083	49

- Comfortable adjustment with extremely stable outlet pressure
- At types 1-4 of the LTD-1 based pressure control units the pilot pressure controller has a drilling in the housing to allow for a relief of the dome chamber to the set value in the case of a pressure relief. The escaping gas exhausts uncontrolled to the environment.
- Types 5-8 (design with external feedback, deliverable from PN40) are for unmatched control accuracy even at variable volume flows. Nonetheless

PN40 and PN50 can be used for lower pressures as well (including suitable pressure gauges).

- During pressure relief the dome chamber is relieved by the throttle valve which is installed at the pilot pressure regulator. Additionally a small amount of gas is always escaping from this throttle valve – thus the pilot pressure controller is forced to permanently control a little bit to grant a constant dome chamber pressure. The escaping gas can be guided to safe areas with a (not included) blow off pipe; alternatively the throttle valve can be closed completely and permanently with an (included) inboard grub screw.
- Optionally:
 - Factory certificate Type 2.1
 - Suitable for food gases (FDA)
 - Suitable for medical gases and for medical oxygen
 - Versions in Stainless Steel



Configuration

Each pressure control unit is configured individually. Please name gas type, upstream and downstream pressure.

Depending on this the components are chosen:

- Dome loaded pressure controller LTD-1 low pressure or middle pressure
- Elastomer Viton or EPDM
- Pilot pressure controller depending on the adjustable range
- Pressure gauge with optimal readability of the adjustable range
- Compliance with specific rules (O₂, medicine etc.)

Pressure control unit: Highest outlet pressure stability especially for fluctuating demands

Retrofit kits LTD-1

- Retrofit kits for existing dome loaded pressure controller are usually deliverable from stock.
- Retrofit kits with outlet pressure gauge for LTD-1 dome loaded pressure controller with manufacturing year before 2015 can only be installed by us. Please contact us.

1	2	3	4																																																
<table border="1"> <thead> <tr> <th>P1 max barg</th> <th>Art-Nr</th> <th>P2 max barg</th> </tr> </thead> <tbody> <tr> <td>25</td> <td>3-8216</td> <td>16</td> </tr> <tr> <td>40</td> <td>3-8217</td> <td>25</td> </tr> <tr> <td>50</td> <td>3-8218</td> <td>49</td> </tr> </tbody> </table>	P1 max barg	Art-Nr	P2 max barg	25	3-8216	16	40	3-8217	25	50	3-8218	49	<table border="1"> <thead> <tr> <th>P1 max barg</th> <th>Art-Nr</th> <th>P2 max barg</th> </tr> </thead> <tbody> <tr> <td>25</td> <td>3-8226</td> <td>16</td> </tr> <tr> <td>40</td> <td>3-8227</td> <td>25</td> </tr> <tr> <td>50</td> <td>3-8228</td> <td>49</td> </tr> </tbody> </table>	P1 max barg	Art-Nr	P2 max barg	25	3-8226	16	40	3-8227	25	50	3-8228	49	<table border="1"> <thead> <tr> <th>P1 max barg</th> <th>Art-Nr</th> <th>P2 max barg</th> </tr> </thead> <tbody> <tr> <td>25</td> <td>3-8236</td> <td>16</td> </tr> <tr> <td>40</td> <td>3-8237</td> <td>25</td> </tr> <tr> <td>50</td> <td>3-8238</td> <td>49</td> </tr> </tbody> </table>	P1 max barg	Art-Nr	P2 max barg	25	3-8236	16	40	3-8237	25	50	3-8238	49	<table border="1"> <thead> <tr> <th>P1 max barg</th> <th>Art-Nr</th> <th>P2 max barg</th> </tr> </thead> <tbody> <tr> <td>25</td> <td>3-8246</td> <td>16</td> </tr> <tr> <td>40</td> <td>3-8247</td> <td>25</td> </tr> <tr> <td>50</td> <td>3-8248</td> <td>49</td> </tr> </tbody> </table>	P1 max barg	Art-Nr	P2 max barg	25	3-8246	16	40	3-8247	25	50	3-8248	49
P1 max barg	Art-Nr	P2 max barg																																																	
25	3-8216	16																																																	
40	3-8217	25																																																	
50	3-8218	49																																																	
P1 max barg	Art-Nr	P2 max barg																																																	
25	3-8226	16																																																	
40	3-8227	25																																																	
50	3-8228	49																																																	
P1 max barg	Art-Nr	P2 max barg																																																	
25	3-8236	16																																																	
40	3-8237	25																																																	
50	3-8238	49																																																	
P1 max barg	Art-Nr	P2 max barg																																																	
25	3-8246	16																																																	
40	3-8247	25																																																	
50	3-8248	49																																																	
5	6	7	8																																																
<table border="1"> <thead> <tr> <th>P1 max barg</th> <th>Art-Nr</th> <th>P2 max barg</th> </tr> </thead> <tbody> <tr> <td>40</td> <td>3-8257</td> <td>25</td> </tr> <tr> <td>50</td> <td>3-8258</td> <td>49</td> </tr> </tbody> </table>	P1 max barg	Art-Nr	P2 max barg	40	3-8257	25	50	3-8258	49	<table border="1"> <thead> <tr> <th>P1 max barg</th> <th>Art-Nr</th> <th>P2 max barg</th> </tr> </thead> <tbody> <tr> <td>40</td> <td>3-8267</td> <td>25</td> </tr> <tr> <td>50</td> <td>3-8268</td> <td>49</td> </tr> </tbody> </table>	P1 max barg	Art-Nr	P2 max barg	40	3-8267	25	50	3-8268	49	<table border="1"> <thead> <tr> <th>P1 max barg</th> <th>Art-Nr</th> <th>P2 max barg</th> </tr> </thead> <tbody> <tr> <td>40</td> <td>3-8277</td> <td>25</td> </tr> <tr> <td>50</td> <td>3-8278</td> <td>49</td> </tr> </tbody> </table>	P1 max barg	Art-Nr	P2 max barg	40	3-8277	25	50	3-8278	49	<table border="1"> <thead> <tr> <th>P1 max barg</th> <th>Art-Nr</th> <th>P2 max barg</th> </tr> </thead> <tbody> <tr> <td>40</td> <td>3-8287</td> <td>25</td> </tr> <tr> <td>50</td> <td>3-8288</td> <td>49</td> </tr> </tbody> </table>	P1 max barg	Art-Nr	P2 max barg	40	3-8287	25	50	3-8288	49												
P1 max barg	Art-Nr	P2 max barg																																																	
40	3-8257	25																																																	
50	3-8258	49																																																	
P1 max barg	Art-Nr	P2 max barg																																																	
40	3-8267	25																																																	
50	3-8268	49																																																	
P1 max barg	Art-Nr	P2 max barg																																																	
40	3-8277	25																																																	
50	3-8278	49																																																	
P1 max barg	Art-Nr	P2 max barg																																																	
40	3-8287	25																																																	
50	3-8288	49																																																	

- Retrofit kits for O₂ only up to 40 barg
- These retrofit kits are often as well deliverable for dome loaded pressure controllers of other producers, e.g. Buschjost / IMI / GHR types C1 and C31. Please contact us.
- Environment friendly wooden box for the safe shipping
 - For 1 pressure control unit:
Art.-no.: 9-000324
 - For 2 pressure control units:
Art.-no.: 9-000326

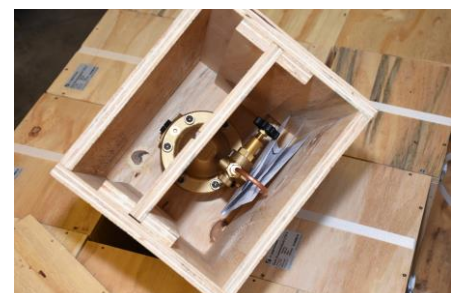

LTD-1 pressure control panels – bespoke solutions

The proven dome loaded pressure controller LTD 1 is as well available in different versions as pressure control panel in standard versions:

- Pressure control station with bypass with pressure control unit type 8, without panel



- Pressure control panel with bypass with pressure control unit type 1, mounted on stainless steel panel:



- Pressure control panel with pressure control unit type 3 with safety valve without bypass mounted on stainless steel panel with roof



- Pressure control panel with pressure control unit type 1 with filter (contamination degree indicated with pressure gauge) with bypass, in- and outlet pressure gauge

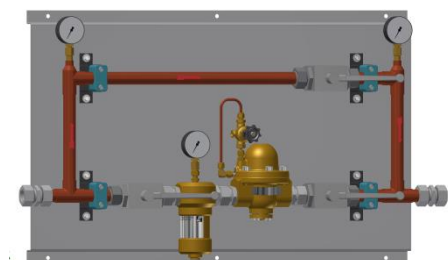

***Cut in half assembly time with our pressure control panels!
LT pressure control panels for particularly quick assembly***

- Redundant pressure control panel with pressure control unit type 5 with in- and outlet pressure gauge, mounted on stainless steel panel with roof

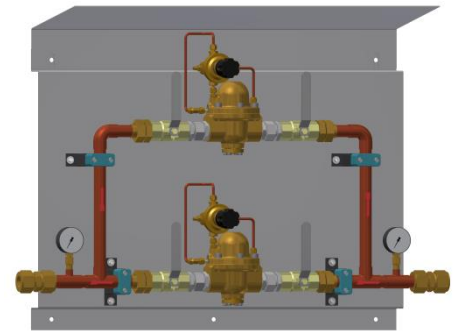

- Redundant pressure control panel with pressure control unit type 5 with in- and outlet pressure gauge with filter mounted on stainless steel panel with roof

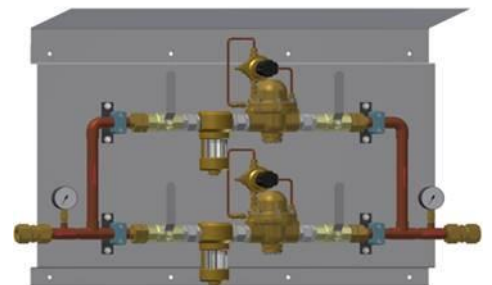

- Redundant pressure control panel with pressure control unit type 7 with filter, in- and outlet pressure gauge mounted on stainless steel panel with safety valve – connection top

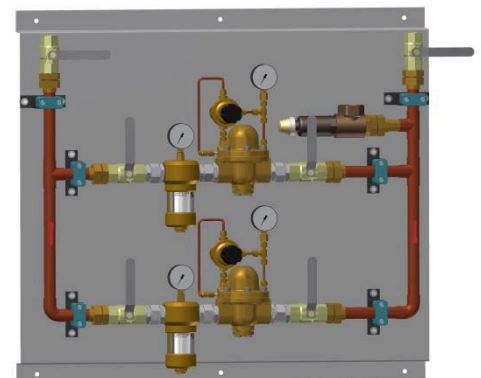

***Assembled and tested, ready for connection and operation,
delivered to your construction site - for quick and easy installation***

LTD-1 with safety valve

Pressure control units can as well be delivered with suitable safety valve **examples:**

- Pressure control unit type 8 with suitable safety valve and soldering screw joint at in- and outlet

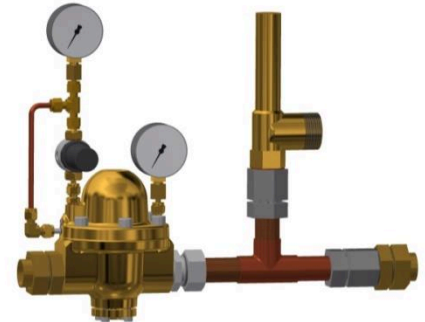

- Pressure control unit type 8 with safety valve mounted on stainless steel panel and flange connection

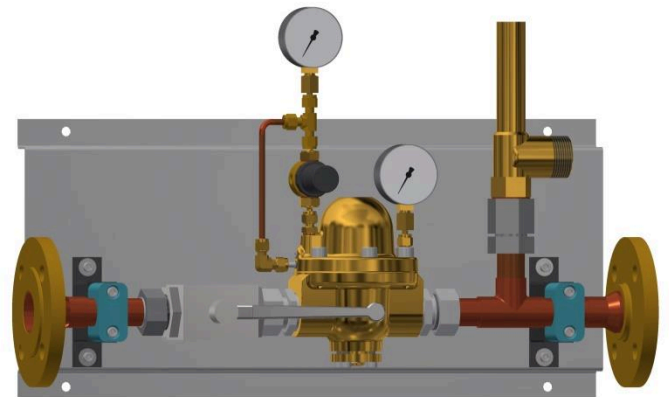

- Redundant pressure control system on stainless steel panel with two 1" pressure control units type 5 and two safety valves, piping and connection flange in stainless steel.

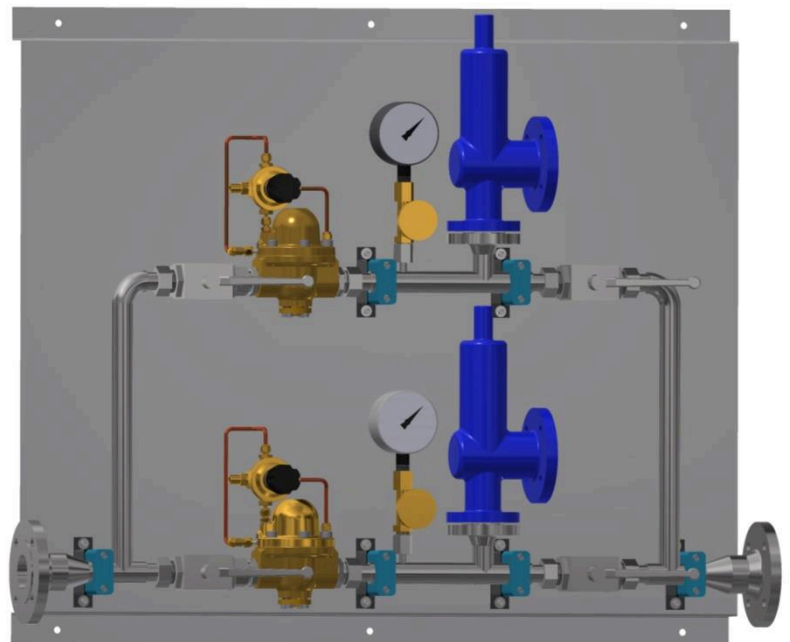

LT pressure control panels are tailor-made solutions based on a modular selection concept

Special versions

We would be happy to manufacture your special version. Below picture shows an example of a configuration for two different gases (hydrogen and nitrogen) on a panel, redundant, with safety valves, filters and pressure common control

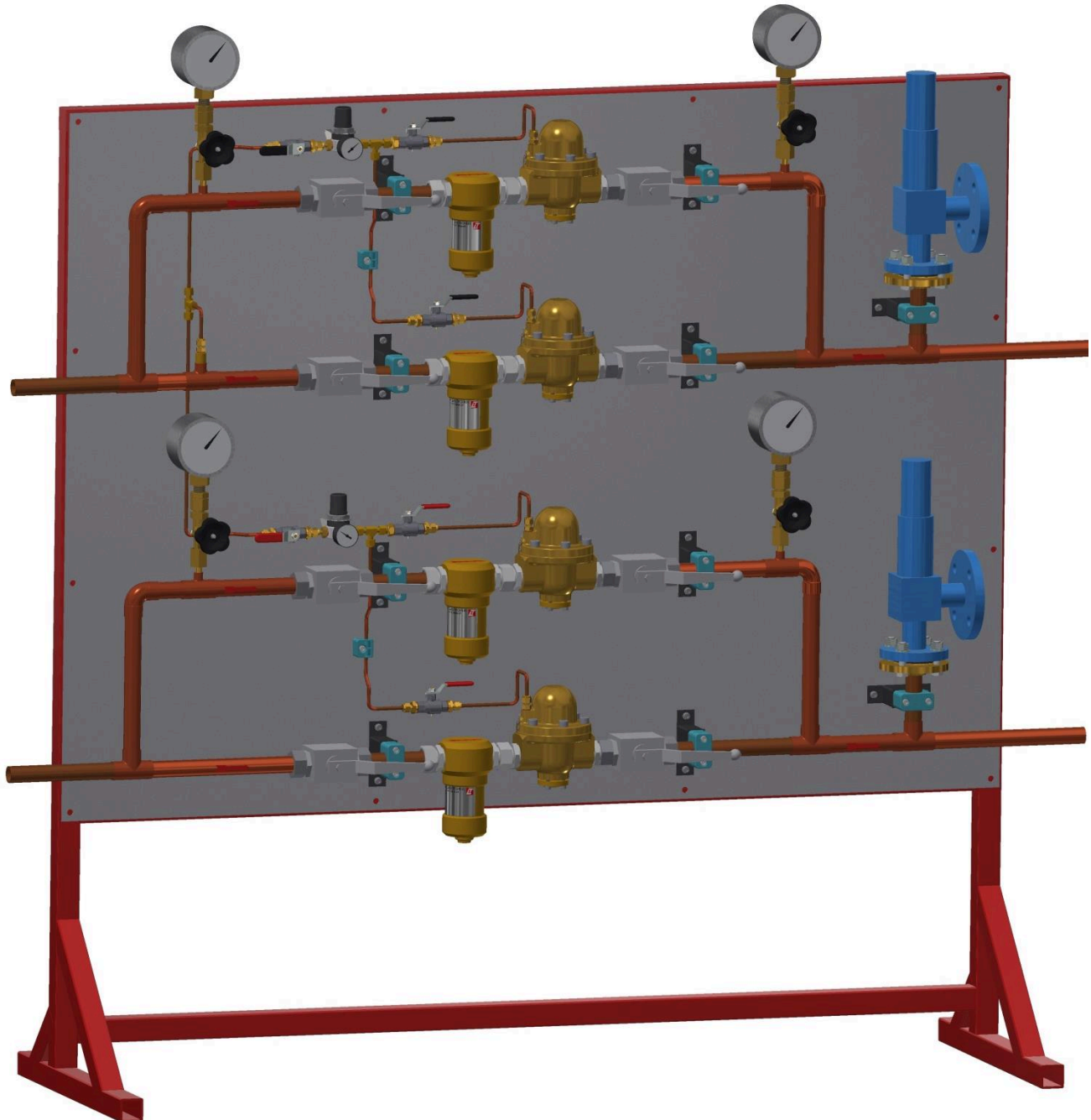

Lots of examples about pressure control units and panels on
www.lt-gasetechnik.com

Versions LTD-2

LTD-2 pressure control unit

- Common version of the 2" pressure control unit as shown, with pilot pressure controller, outlet pressure gauge including loose flange with mounting boss
pressure control unit LTD-2 type 1, PN25:
Art.-no.3-7533
pressure control unit LTD-2 type 1, PN40:
Art.-no. 3-7532

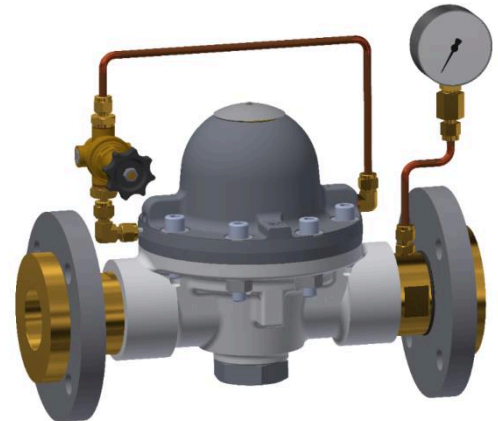

LTD-2 pressure control panels

- 2" pressure control panel with bypass with pressure control unit type 1, with in- and outlet gauge, mounted on stainless steel panel
- Redundant 2" pressure control panel with pressure control unit type 3, mounted on stainless steel panel

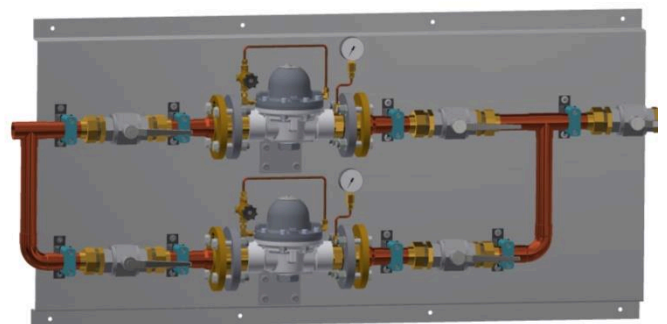
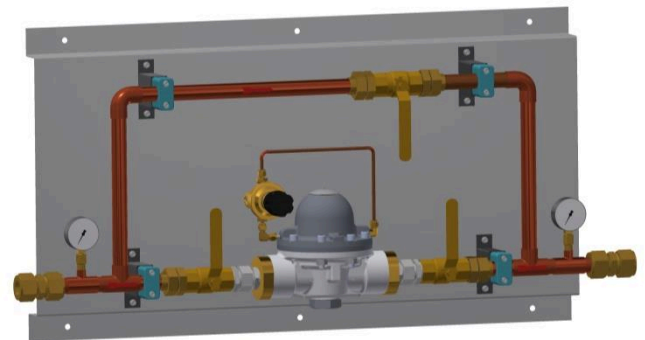

***Impressive: With these pressure control panels
you cut in half setup time and costs!***

LTD-2 with safety valve

2" pressure control units are as well available with suitable safety valve:

- 2" Pressure control unit type 2, large outlet pressure gauge, with safety valve including loose flanges, mounted on stainless steel panel

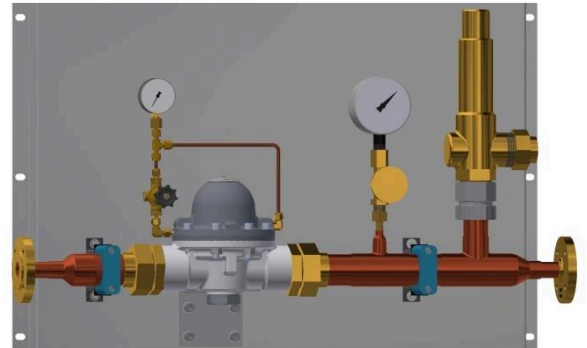

Versions LTD-3

3" dome loaded pressure controller are available in the versions as shown before – for the safe mounting we recommend installation on a frame.

Pressure control system on basis of the dome loaded pressure controller LTD-3 with pilot pressure controller, pressure gauge for inlet and outlet pressure, flange ball valve DN50 stainless steel, safety valve, completely mounted on frame and 100% tested for quick and easy installation

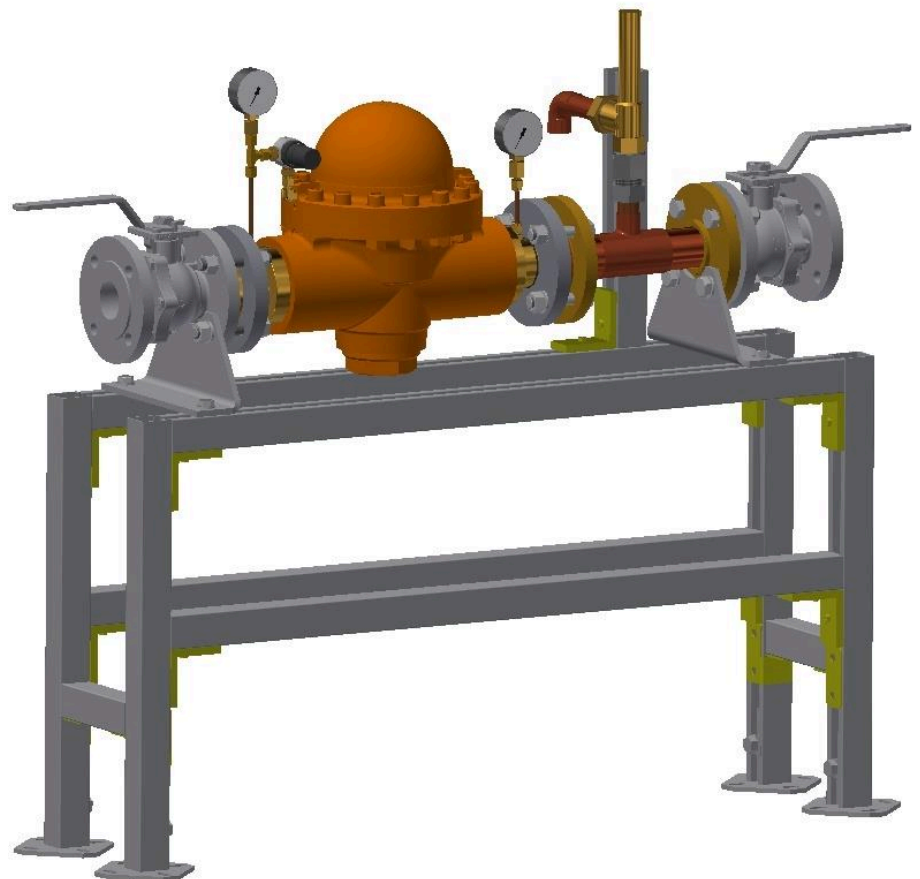

***Only a few possible variants are shown here;
contact us for your individual solution!***

Data sheet dome loaded pressure regulator LTD-1

Precise and instantaneous pressure control without “wobbling“ even with large variations

- For almost all technical gases, air and liquids
- Performance: 10 ... 2,500 Nm³/h
- Maximum inlet pressure:
 - ND: Inlet: 25 barg Outlet: 0.1 .. 24 barg
 - MD: Inlet: O₂ 40 barg, other gases 100 barg
Outlet: O₂: 0.5 ... 39 barg, other gases 0.5 ... 99 barg
 - HD: Inlet: 414 barg Outlet: 28...138 barg
- Sealing material:
 - Viton: -20°C ...100 °C for O₂, and all technical gases except acetylene and CO₂
 - EPDM: -40°C ... 130 °C for CO₂ and all neutral gases (not for O₂)
- Weight: Brass: 6 kg; Stainless Steel: 13 kg; SS high pressure 9.9 kg
- Connection inlet and outlet: G 1" RH - female
- Safety function: closed by spring force and positive tightening
- Materials: Brass; brass nickel plated; stainless steel
- Options:
 - Suitable for food (acc. to Regulation (EC) No. 1935/2004)
 - Suitable for medical applications (according to the requirements of DIN EN ISO 15001:2012-06)
 - pressure control units or pressure control systems
- Dimensions LTD-1 brass:

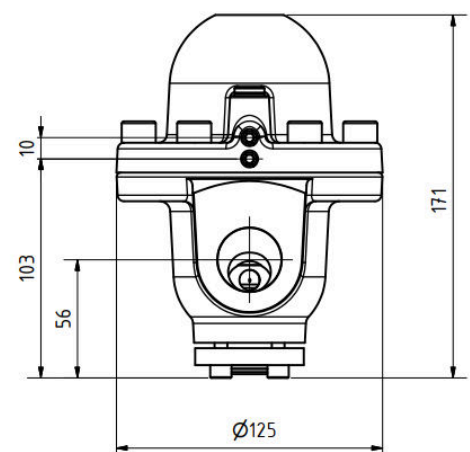
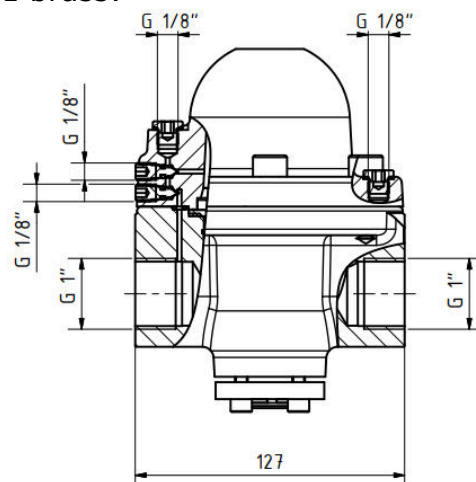
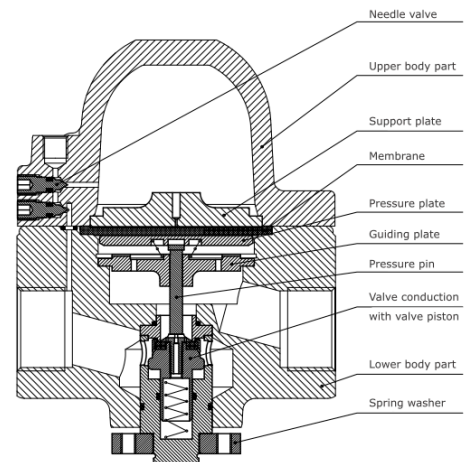

Performance diagram LTD-1 brass

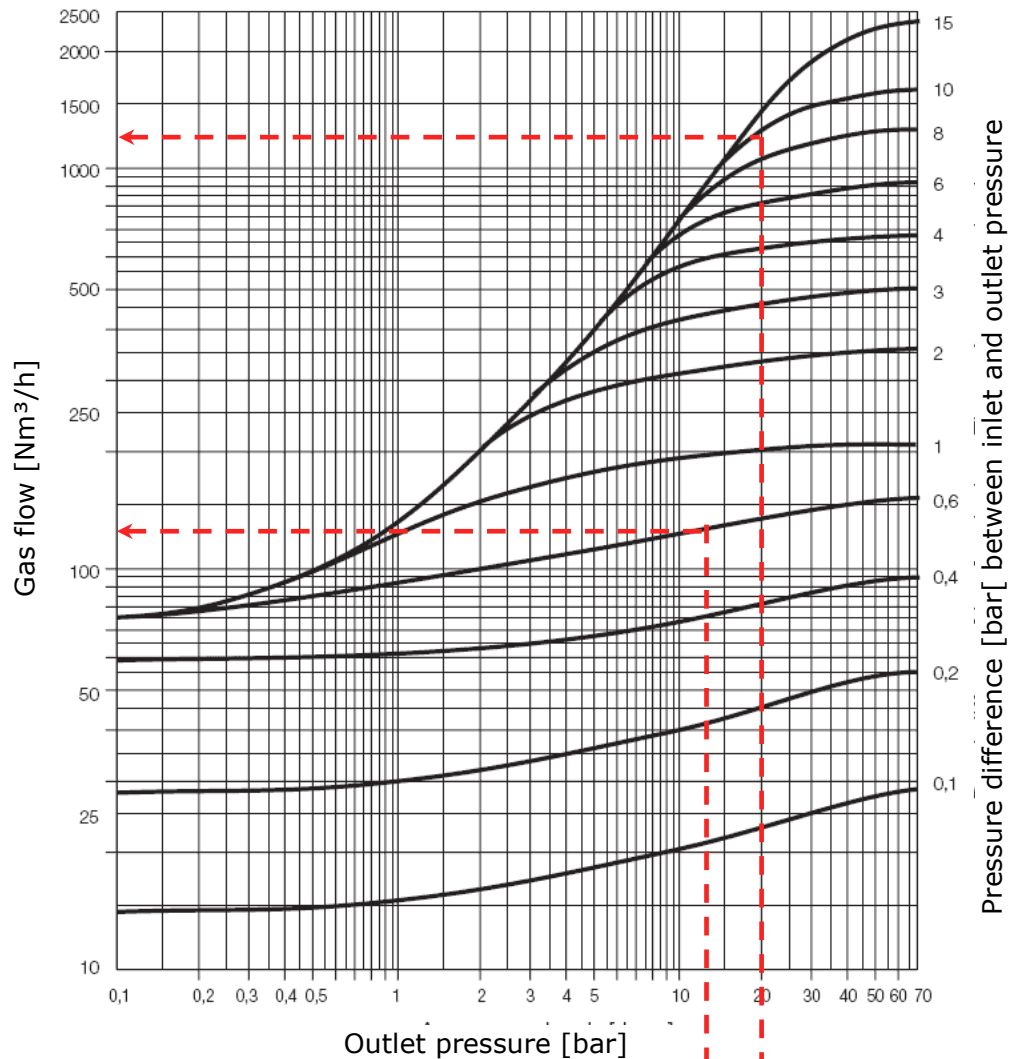

Conversion factors:

- Oxygen: 0.95
- Hydrogen: 3.80
- Propane: 0.80
- Carbon dioxide: 0.81
- Dinitrogen monoxide: 0.80
- Nitrogen: 1.00
- Argon: 0.85
- Helium: 2.70

Example 1:

Pressure reduction from 13.6 bar to 13.0 barg. The gas flow amounts to approx 130 Nm³/h Air = 494 Nm³/h Hydrogen

Example 2:

Pressure reduction from 30 to 20 barg. Gas flow approx. 1,240 Nm³/h air, equal to 1,000 Nm³/h Propane

Kv-value = 2.9

Note: Performance values for the LTD-1 can only be calculated approximately using the Kv value (results are higher than the reading from the diagram), since the diagram includes the special properties of the housing and the Kv value considers only the diameter of the valve seat.

Data sheet dome loaded pressure regulator LTD-2

Precise and instantaneous pressure control without “wobbling“ even with large variations



- For almost all technical gases, air and liquids
- Performance: 10 ... 5,000 Nm³/h
- Maximum inlet pressure: 0.5...69 bar
- Maximum outlet pressure: 0.1...65 bar
- Sealing material: EPDM for membrane and seal
- Temperature range: -20 ... 70°C
- Weight Aluminum alloy: 6.4 kg
- Flow coefficient:
 - $C_v = 8.0$
 - $K_v = 8.3$

Conversion factors:

- Oxygen:	0,95
- Hydrogen:	3,80
- Propane:	0,80
- Carbon dioxide:	0,81
- Dinitrogen monoxide:	0,80
- Nitrogen:	1,00
- Argon:	0,85
- Helium:	2,70

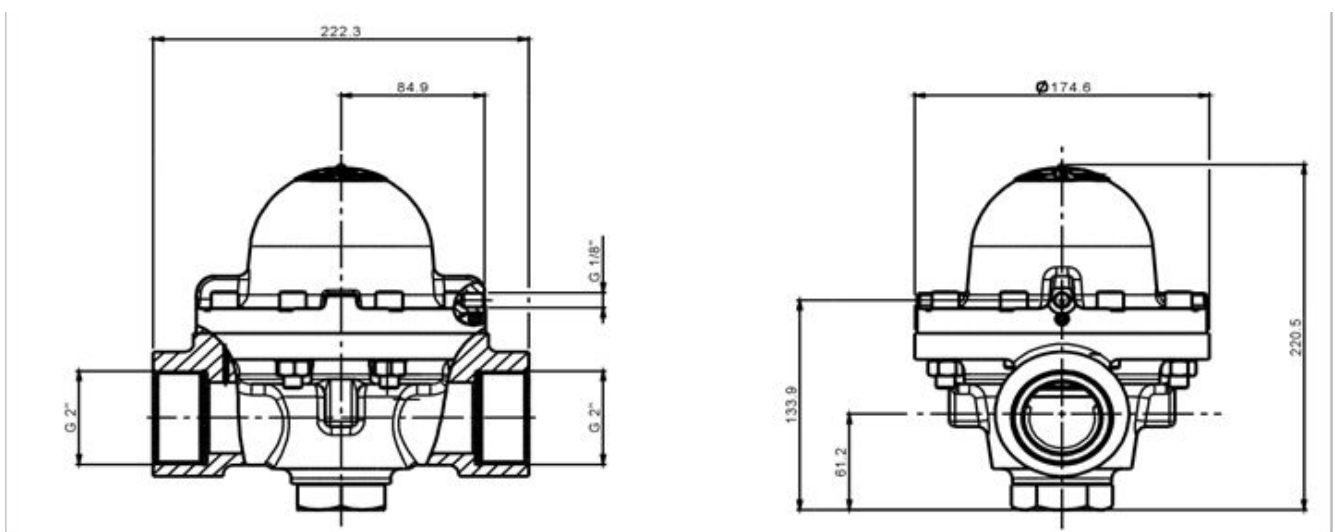

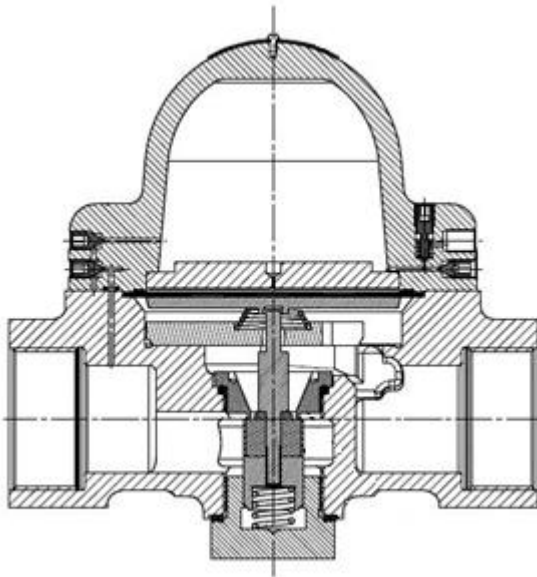

- Installation length approx. 222 mm, height approx. 220 mm
- Connection inlet and outlet:
G 2" RH – female
Optionally flange DN50 PN40
- Safety function: closed by spring force and positive tightening
- Options:
Factory certification acc. to EN 10204
- Materials: aluminum alloy

Also available as:

- Pressure Control System with
 - Inlet and outlet stop valve
 - Bypass
 - Pressure gauge (inlet pressure and/or outlet pressure)
as well as pressure transmitter
 - Control by pilot pressure controller
as well with external recirculation
 - Safety valve
 - Gas filter
 - Mounted on wall console or rack,
as well with roof
- Dome loaded pressure control unit with
 - Control by pilot pressure controller
as well with external recirculation
 - Pressure gauge (inlet pressure
and/or outlet pressure)





About LT GASETECHNIK

Integrated in the weyer group and based in Dortmund, Germany since 1971, we develop and supply high-performance gas mixing equipment, serial gas mixers, serial valves and tailor-made control solutions. We manufacture standard equipment, as well as custom-designed systems with the highest standards of engineering, safety and quality. Complex technical requirements are at the same time for us stimulation and incentive – just beyond standards

Our customers

We supply plants and fittings for a wide variety of industries and industrial applications. Our customers include not only all the world's leading manufacturers of industrial gases, but also many companies from the following sectors:

- Machine and plant engineering
- Automotive industry
- Chemical industry
- Electronics, Measurement, Control and Analysis technology
- Ferrous / Non-Ferrous Metals
- Energy supply
- Liquefied gases
- Glass industry (float glass and flacons)
- High-tech industry
- Industrial gases
- Food industry
- Pharmaceutical industry

They all rely – typically since many decades - on our experience and our extensive and well-founded know-how. Our team of engineers from the fields of process engineering, design/planning and C&I-technology develops a practical and efficient solution in every single case, which, of course, also meets special requirements.

Member of the weyer group

LT GASETECHNIK is a member of the weyer group. Klaus Weyer is Managing Director at horst weyer and partner GmbH as well as at L+T GASETECHNIK Klöpfer-Waldmann GmbH & Co. KG.

Overview of the weyer group:

- Founded 1976
- 4 countries
- 10 companies
- 17 sites
- More than 160 employees (plus employees of GASETECHNIK)
- More than 900 projects per year (plus LT GASETECHNIK projects)
- Customer industries: Chemical, Pharma, Oil, Supply and Disposal, as well as organizations and public authorities
- Services: Engineering and consulting in and around industrial plants
- Approx. 35 experts in the areas of waste, fire protection, explosion protection, emission control, water protection, business valuation, old loads, evaluation of machinery and industrial equipment, accident and radiation protection

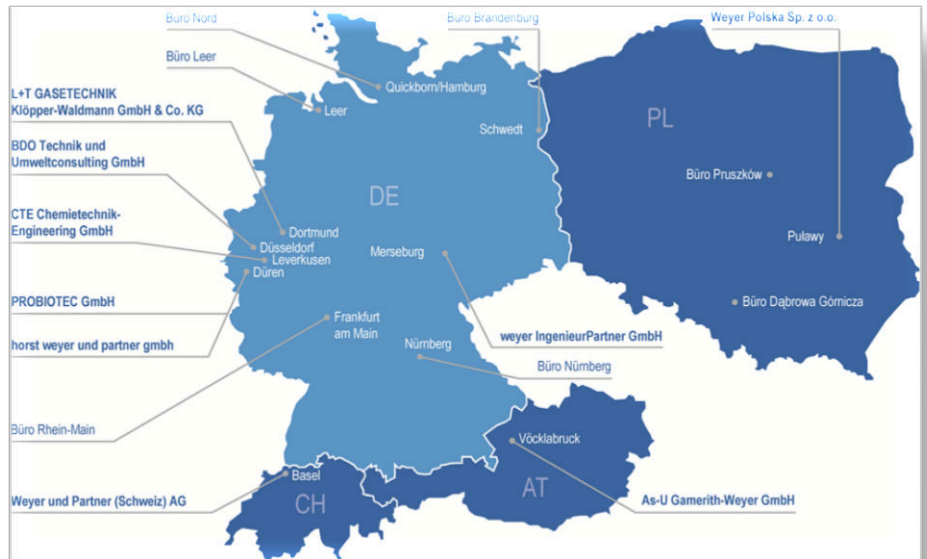

LT GASETECHNIK – integrated in a strong group

The weyer group covers all aspects of engineering and consulting in the area of process and environmental technology. The team of experienced process engineers, natural scientists, process control technicians and business consultants develops, plans and implements individual projects in process and safety engineering and computer engineering. The extensive portfolio of the weyer group, thematic specializations on individual subject areas, references and information about the members of the weyer group can be found on www.weyer-gruppe.com



Supply range LT GASETECHNIK

This supply range only gives in an overview. Please contact us if you cannot find what you are looking for. We will be more than happy to work out your **individual solution** beyond standards together with you – just **beyond standards**:

Gas Process Plants

- Engineering, production and commissioning of Gas Mix, Gas Supply and Test Systems according to customer specifications
- Dynamic high-performance systems with associated electrical, measurement, control equipment and gas analysis systems.
- Customized Gas Process Plants

Gas Mixing Technology

- Gas mixer for flammable and non-combustible gases
- Static gas mixers with and without buffer vessel
- Dynamic, MFC-based, fully automated gas mixer
- Gas analysis systems

Gas related equipment

- Pressure regulators, pressure regulating stations and pressure control units
- Bottle and bundle battery systems
- Valves and gas filters
- Gas safety devices

E/C&I and analysis technology

- Individual solutions for control and regulation tasks
- Engineering, field cabinet design, PLC-software design
- Technical process engineering C&I
- Gas analyzers
- Standard equipment and systems for gas applications

Individually configurable – custom-fit for your needs



Your personal contact

Miroslav Popovic

Mail: m.popovic@lt-gasetechnik.com

Direct call: +49 231 96 10 70-42



LT GASETECHNIK

beyond standards

Martener Str. 535 – 44379 Dortmund – Germany

Tel +49 231 / 96 10 70-0 Fax +49 231 / 61 38 44

www.lt-gasetechnik.com mail@lt-gasetechnik.com