

Data sheet

dome loaded pressure controller LTD-2

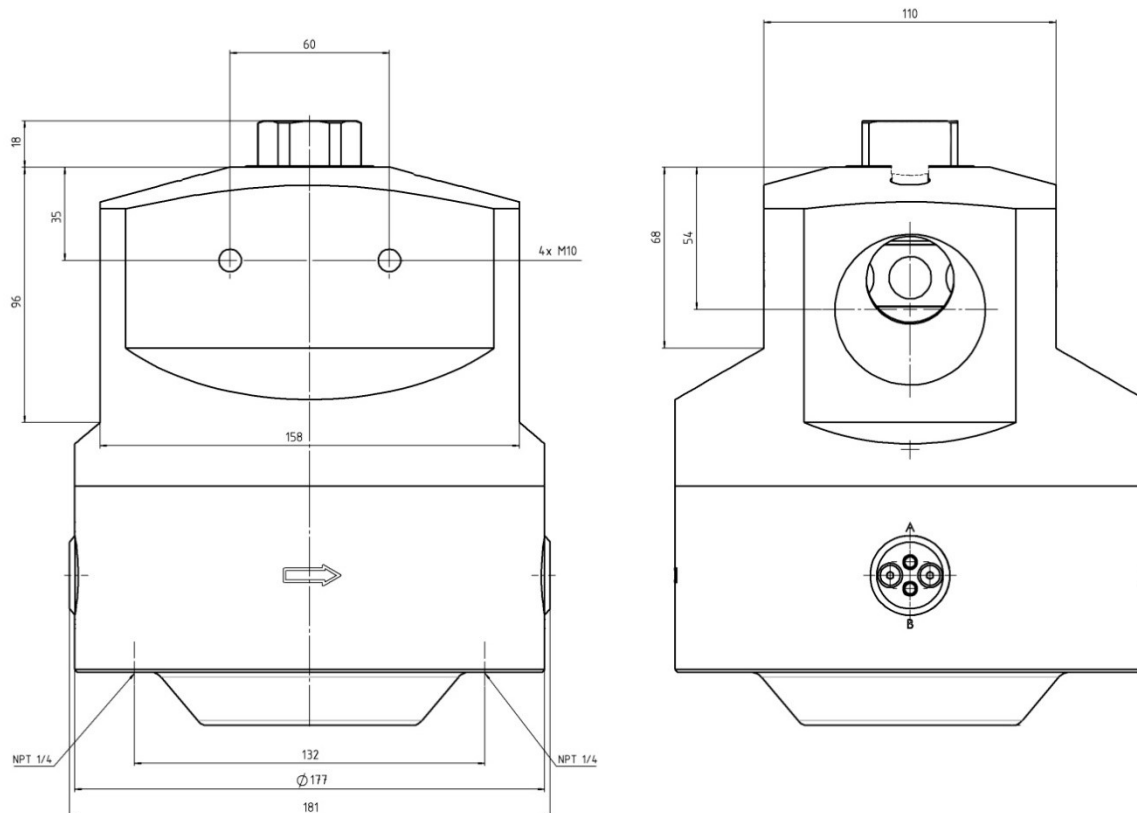

Item numbers: 3762000, 3762100, 3762200

- Available materials: brass or stainless steel
- Sealing materials:
EPDM or FKM for O-rings and membrane
- Suitable for almost all technical gases, air and liquids
- Maximum inlet pressure 110 bar
- Control range ND up to 12 bar
Control range MD up to 100 bar
- Flow coefficient $C_v = 17.7$
- Standard temperature range: $-40 + 150 \text{ }^\circ\text{C}$
- Weight: approx. 27 kg
- Installation length approx. 181 mm, height approx. 228 mm
- Connection inlet and outlet: internal thread G2 "RH

The dome loaded pressure controller LTD-2 is a pneumatically controlled, single-stage pressure regulator that was developed for use with compressed gases and gas mixtures. Permissible gases are all technical gases except acetylene.

We recommend a fine filter upstream. If the pressure level changes, the downstream components must be protected by safety valve(s)

The dome pressure can be derived from the upstream pressure side through needle valves.

A pilot valve or a proportional valve can be used for convenient adjustment. Further details in the operating instructions.

Optionally available with

- Fine filter
- Factory certificate according to EN 10204 (item no. 6220000)
- Screw-in socket with loose flange DN50 PN40 (item no.3770000)
- Pressure gauges for inlet pressure and outlet pressure, also as a pressure transmitter
- Wall bracket
- Pressure control unit controlled by a pilot pressure regulator, also with external back pressure feedback
- Pressure control system with shut-off on the inlet and outlet side, bypass, safety valve, gas filter. On wall panel and/or stand for floor installation, w/wo roof

